

USE OF GASKETS

FOR 1/4" (6mm) GLASS: USE ONE THICK GASKET ON EACH SIDE

FOR 5/16" (8mm) GLASS: USE ONE THIN GASKET ON EACH SIDE

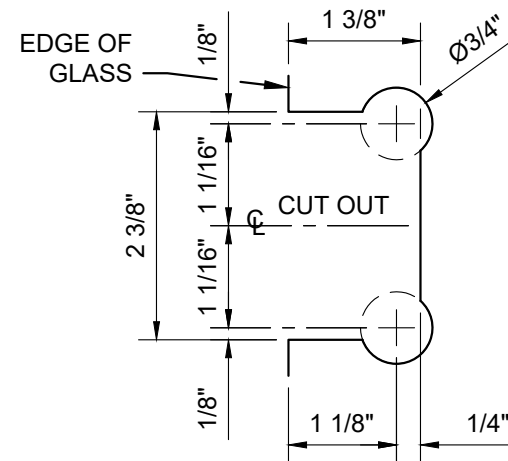
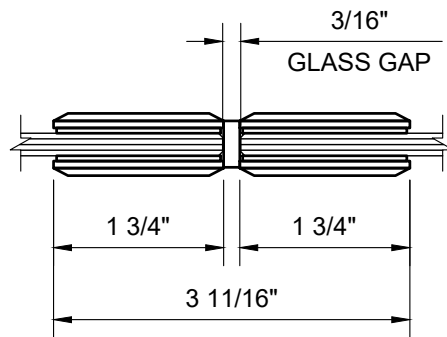

GLASS FABRICATION TEMPLATE

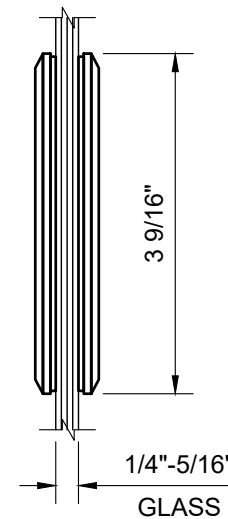
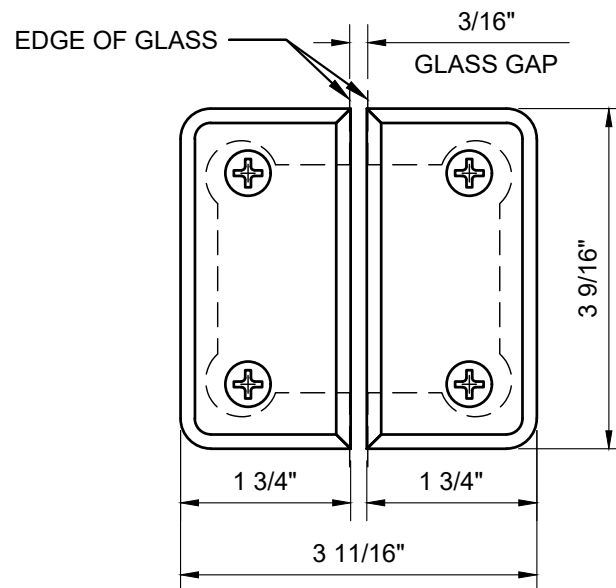

CATALOG NUMBER	FINISH
PET180CH	POLISHED CHROME
PET180BR	POLISHED BRASS
PET1800RB	OIL RUBBED BRONZE
PET180BN	BRUSHED NICKEL
PET180GP	GOLD PLATE
PET180SC	SATIN CHROME

PET180XX - CRL PETITE SERIES 180 DEGREE GLASS TO GLASS HINGE

DATE: 3/7/19
SCALE: 6"=1'-0"
DRAWN BY: VM

DESCRIPTION: CRL PETITE SERIES HINGE
PET180__ 180° GLASS TO GLASS HINGE

C.R. LAURENCE CO. ARCHITECTURAL PRODUCTS
2503 E. Vernon Avenue, Los Angeles, CA 90058-1897
PH (800)-421-6144 FX: 800-587-7501 www.crlaurence.com

