

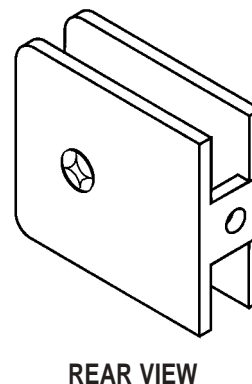

C.R. LAURENCE CO., INC.
 PROFESSIONAL QUALITY

GLASS CLAMPS
 Junior Fixed Panel U-Clamp
 CAT. No. UC66

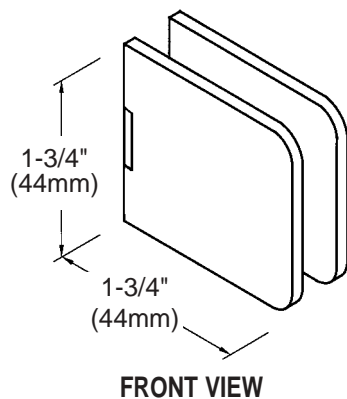

Specifications:

Material: Solid brass
Glass Thickness: 1/4" (6mm)
Hole Size Required: 5/8" (16mm) or 3/4" (19mm)
Includes: Mounting screws and gaskets

Template Shown on Next Page

GLASS CLAMPS
 Fixed Panel U-Clamp
 CAT. No. UC77

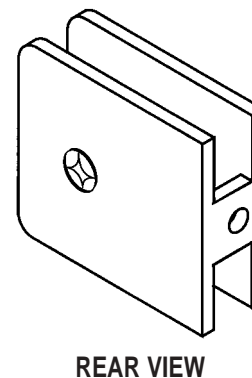
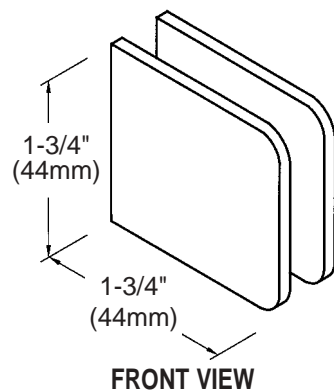

Specifications:

Material: Solid brass
Glass Thickness Range: 5/16" (8mm) to 1/2" (12mm)
Hole Size Required: 5/8" (16mm) or 3/4" (19mm)
Includes: Mounting screws and gaskets
Note: An additional set of gaskets is required for 5/16" (8mm) glass

Template Shown on Next Page

GLASS CLAMPS
 Monaco Glass Clamp
 CAT. No. MO638

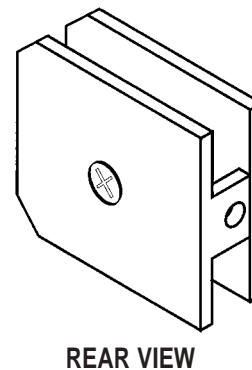
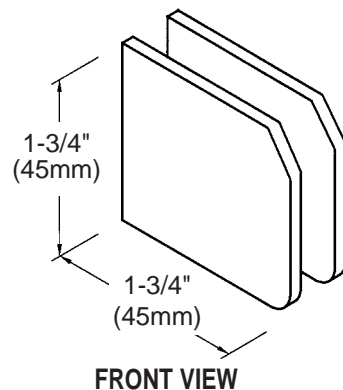

Specifications:

Material: Solid brass
Glass Thickness Range: 1/4" (6mm) to 5/16" (8mm)
Hole Size Required: 5/8" (16mm) or 3/4" (19mm)
Includes: Mounting screws and gaskets

Template Shown on Next Page



C.R. LAURENCE CO., INC.
PROFESSIONAL QUALITY

TYPICAL INSTALLATION

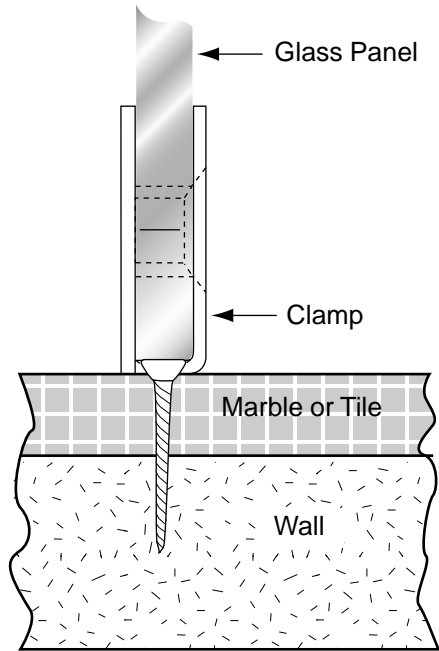

END VIEW

GLASS CLAMPS

Junior Fixed Panel U-Clamp

CAT. No. UC66

Fixed Panel U-Clamp

CAT. No. UC77

Monaca Glass Clamp

CAT. No. M0638

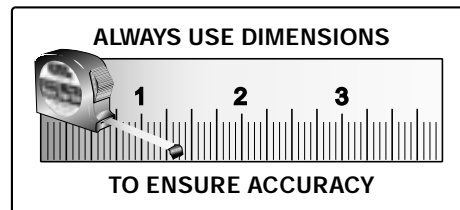

TEMPLATE

Important: Project measurements from the edge of the glass.

